

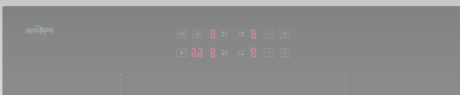

IWSH6041CAUS

60CM 4 ZONE BUILT-IN INDUCTION COOKTOP

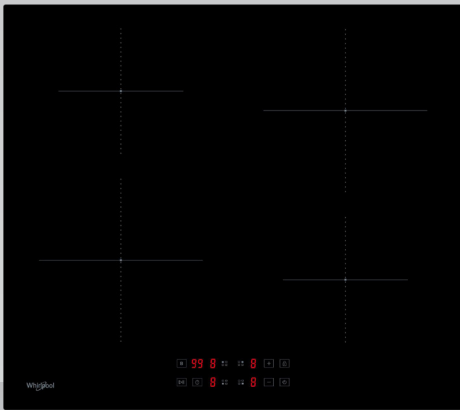

FEATURES & BENEFITS



INDUCTION TECHNOLOGY

Induction technology heats the pan, not the hob, reducing energy dispersion as well as achieving faster and energy-efficient cooking.

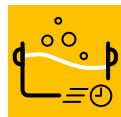

BOOSTER

Thanks to the Booster function which the cooking zones of the hob are equipped with, boiling times are significantly reduced.



STOP & GO

Suspend the cooking process if you're interrupted then re-start again at the same temperature in an instant with the Stop & Go function.



BLACK CERAMIC GLASS

A completely smooth cooking surface makes the cooktop extremely easy to clean with just a wipe.



CHILD LOCK

Featuring a Child Lock function to prevent toddlers and children from accidentally using the hob.



WARRANTY

5 Year warranty on parts and labour.

TECHNICAL SPECIFICATIONS

TYPE	60cm Built-in Induction Hob
COOKING ZONES	4
COLOR / FINISH	Black Ceramic Glass
CONTROL	Touch Control
LOCATION OF CONTROL PANEL	Front
PRODUCT NET WEIGHT	8.4kg
PRODUCT DIMENSION	W 590mm x H 56mm x D 520mm
CUT-OUT DIMENSION	W 560mm x D 500mm
FUNCTIONS	Booster, Stop & Go Function
FEATURES	Child Lock, Timer, Pan Detection, Residual Heat Indicator, Auto Shutdown, Over-heat Protection, Over-flow Protection
TOTAL POWER	7,200W
LEFT, FRONT ZONE	2,000W (Booster 3,000W)
LEFT, REAR ZONE	1,500W (Booster 2,000W)
RIGHT FRONT ZONE	1,500W (Booster 2,000W)
RIGHT REAR ZONE	2,000W (Booster 3,000W)
POWER SETTING	9 levels
ENERGY INPUT	Electric
POWER VOLTAGE	220-240V or 380-415V 3N~, 50-60Hz
LENGTH OF POWER CORD	110cm (without plug)
PACKAGING DIMENSION	W 635mm x H 113mm x D 568mm
GROSS WEIGHT	10kg
COUNTRY OF ORIGIN	Asia
EAN	4895120710870
WARRANTY	5 Years

INSTALLATION GUIDE

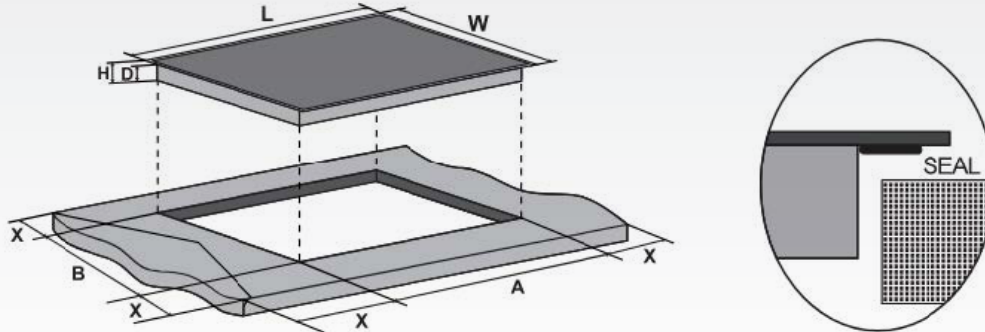

INDICATION	L	W	H	D	A	B	X
DIMENSION	590mm	520mm	56mm	52mm	560mm	500mm	50mm

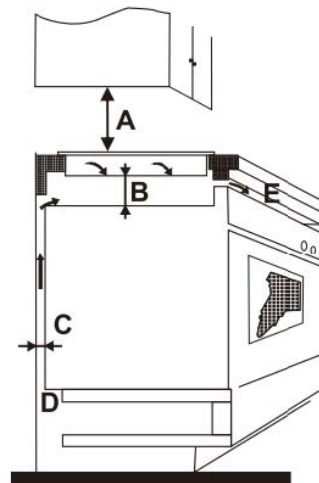

INDICATION	A	B	C	D	E
DIMENSION	760mm (min.)	50mm (min.)	20mm (min.)	20mm (Air inlet min.)	5mm (Air outlet min.)

CONTROL PANEL

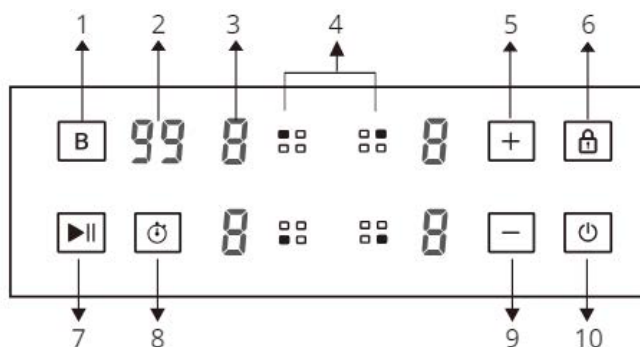

1. Booster function control button
2. Timer indicator
3. Cooking level indicator
4. Cooking Zone selection button
5. Cooking level/Timer "+" control button
6. Child Lock control button
7. Stop & Go control button
8. Timer control button
9. Cooking level/Timer "-" control button
10. ON/OFF button

DISTRIBUTED BY ARISIT PTY LTD

40-50 Mark Anthony Drive, Dandenong South VIC 3175
Ph: 1300 762 219 Fax: 03 9768 0838 Website: www.arisit.com