

# Italian made style in black Ceran®. Electric, with 4 responsive elements.

6AKM613 IX

## 60cm Ceramic Electric Cooktop



- 60cm cooktop
- Black Ceran® easy to clean surface with stainless steel trim
- 4 Quickstar heating elements
- Side controls are special "Lift and Clean" control knobs make this hob very easy to keep clean
- Residual heat indication warn if the hob is hot even when the zone is switched off for safety

- Exclusive to Whirlpool, Green Glass Ceramic Ceran® cooktops. Traditional ceramic cooktops include the heavy metals arsenic and antimony. Arsenic is a toxic chemical naturally found in Silicon (chemical symbol As), and Antimony is a toxic chemical prominent in fire retardants (chemical symbol Sb). The Green Glass symbol means no toxic heavy metals



Number One Appliance Manufacturer in the World.



**Whirlpool®**

GUESS WHOSE MUM'S GOT A WHIRLPOOL?®

[whirlpool.com.au](http://whirlpool.com.au) [whirlpool.co.nz](http://whirlpool.co.nz)

# Dimensions / Installation Guide

6AKM613 IX

## 60cm Ceramic Electric Cooktop

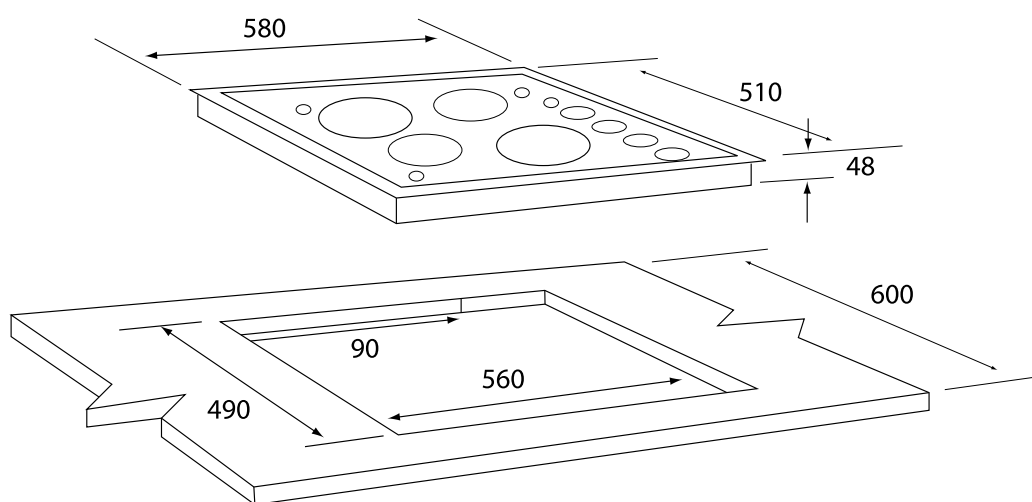

### 6AKM613 IX - Black Ceran®

Appliance H x W x D (mm) 48 x 580 x 510

Cut-out H x W x D (mm) 90 x 560 x 490

| Burner      | Type      | Wattage | Diameter |
|-------------|-----------|---------|----------|
| Front left  | Quickstar | 1200W   | 145mm    |
| Front right | Quickstar | 1700W   | 180mm    |
| Rear left   | Quickstar | 1700W   | 180mm    |
| Rear right  | Quickstar | 1200W   | 145mm    |

For full installation requirements, including cabinetry ventilation please refer to the installation and user manuals with the appliance or on the website: [www.whirlpool.com.au](http://www.whirlpool.com.au)

Number One Appliance Manufacturer in the World.

[whirlpool.com.au](http://whirlpool.com.au) [whirlpool.co.nz](http://whirlpool.co.nz)



GUESS WHOSE MUM'S GOT A WHIRLPOOL?®